

DOI: 10.2478/lpts-2018-0015

MEASUREMENT OF LOW CONCENTRATION OF NANOSIZED
OBJECTS SUSPENDED IN A LIQUID MEDIUM

D. Merkulovs¹, O. Vilitis², V. Kozlovskis³

¹ Institute of Physical Energetics, 11 Krivu Str., Riga, LV-1006, LATVIA

² Institute of Solid State Physics, University of Latvia,
8 Kengaraga Str., Riga, LV-2130, LATVIA

³ Institute of Microbiology and Virology, Riga Stradins University, Science Hub
"Kleisti", 5 Ratsupites Str., Riga, LV-1067, LATVIA

dmitrijs_merkulovs@yahoo.co.uk

The new optical scheme of refractometer with temperature stabilisation 10^{-2} °C is developed, which allows measuring a refractive index of the sample with accuracy not worse than 10^{-5} ; dependence of refraction index on concentration of SiO₂ nanoparticles in liquid suspension is obtained within the framework of the research.

Keywords: *concentration measurement, nanoparticles, refractive index, suspension.*

1. INTRODUCTION

Measurement of nanoparticle concentration is a ubiquitous requirement across a diverse range of applications. Methods of dynamic light scattering and atomic force microscopy are the most known methods to measure concentration and sizes of nanoparticles in suspensions [1]. Refractometers, in turn, are widely used to analyse the composition of transparent binary solutions [2].

Earlier we showed that refractometric methods could also be applied to the analysis of liquid suspensions of nanoparticles, though the received results had qualitative character [3]. In the research [4], it is shown how refractometers can also be applied to the quantitative analysis of concentration of nanoparticles in suspensions.

In the present research, the authors continue their studies on an essentially different refractometer [5], [6], [7]. The aim of this article is to simplify the measurement scheme and reduce the sizes of previous constructions [3], [4], without worsening of the resolution of the device.

2. EXPERIMENTAL SETUP

A schematic cross-section of the cylindrical cell (cuvette) showing a simplified route of the beam in the measuring system is shown in Fig. 1. The refractometer measuring system consists of a laser diode ($\lambda=650$ nm, power

4 mW), a cylindrical thin-walled cell with its cross-section perpendicular to the axis O of the cylinder and a linear image sensor (Hamamatsu CMOS monochromatic linear 1024 pixel image sensor S9226 with the pixel width of 0.0078 mm is used). The cell is filled with distilled water containing nanoparticles. The position a of the beam is identified using a linear CMOS image sensor. The laser beam axis is lined up with the cell outer wall tangent and perpendicular to the axis of the cylinder. The laser beam after refraction at point 1 crosses the medium of the cell wall and arrives at point 2 on the boundary between the material of the cell inner wall and the liquid. The laser beam after refraction at point 1 crosses the medium of the cell wall and arrives at point 2 on the boundary between the material of the cell inner wall and the liquid.

The experiments demonstrated that in the vicinity of the critical angle the beam intensity of light was the highest [2]. For this reason, to illustrate the trajectory of the coherent light beam in the cylindrical cell, Fig. 1 shows only the path of rays that are close to the critical angle. After being refracted at the boundary point 2, light rays travel through the test liquid and, having crossed it, fall upon the inner wall of the cylinder at point 3, where they are refracted again and reach the point Q_1 through the medium of the cell wall. Points 1, 2, 3, Q_1 , 4, Q_2 , Q_3 , Q_4 and Q_5 are reference points, in which the beam is refracted at the interface between two transparent media with different refractive index (RI).

As the outside surface of the cylinder is coated with a reflective film, the rays falling on this unit area of the boundary surface are reflected and intersect the cell wall and the liquid several times in a similar way.

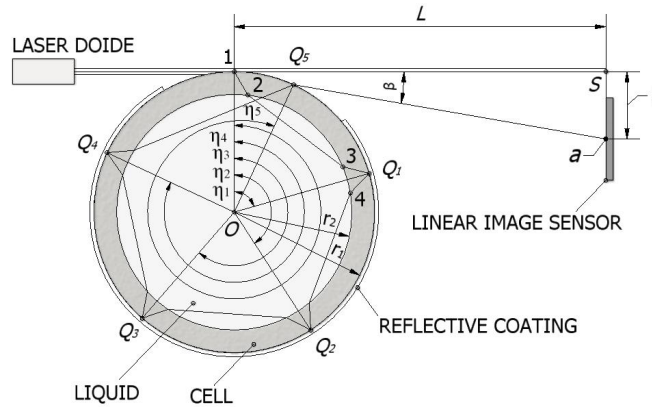

Fig. 1. Schematic cross-section of the cylindrical cell that illustrates a simplified path of the laser beam in the measuring system.

The analytical calculation of the RI of liquids contained in the system described above is given in [8], [9], where applying the laws of light refraction and reflection and using simple trigonometric formulae, the central angle η_m (see Fig. 1 for the case when $m = 5$ – the number of reflections of the laser beam (inside the cuvette) was calculated as follows:

$$\eta_m = 2m[(\pi/2 - \arcsin(k/n_3) + \arcsin(k/n_2) - \arcsin(1/n_2)] \quad \text{rad}, \quad (1)$$

where $k = r_1/r_2$ is the ratio of the outer and inner radii of the cylindrical cell; n_2 and n_3 are the refractive indices of the material of the cell and the liquid, respectively.

Establishing geometric and physical parameters as follows: $r_1=5.46$ mm; $r_2=4.54$ mm, $L=118$ mm, $n_2=1.5$ (glass), $n_3=1.330566\dots1.330347$ (distilled water within 26 °C и 28 °C) [2], it is possible to theoretically calculate the position of the laser beam on a linear image sensor. We obtain $l\approx 17$ mm.

Traditionally, projected on a linear measuring element (for example, on a CMOS linear image sensor), the beam forms an image area containing a front, namely, a transition region from darkness to light. The position of the front is determined by the critical angle of the optical system comprising the cuvette and the liquid being measured. Since the transition between the dark and light parts of the image is gradual, it is necessary to define the position of the boundary [2]. Such an approach, however, has some disadvantages. The distribution of the light intensity on the front depends on the slope of the light intensity graph, the intensity and stability of the light source and the presence of gaseous or other particles in the measured liquid, such as air bubbles. Consequently, the detection of the front position is difficult and sometimes even impossible.

The refractometer proposed by the authors is free from these unsatisfactory features. Waveform of the images shows that the interference of laser light after it is reflected from different regions in the cuvette generates an interference pattern, as described in more detail in [8], [9]. The image position is determined by the position of the first or any subsequent minimum following the position of the maximum intensity of distribution. This is very clearly seen in Fig. 1. The position of the minimum is given by the ordinal number of the corresponding pixel of the linear sensor. It is determined automatically by the microcontroller using traditional methods of the mathematical analysis. As can be seen in Fig. 1, the minimum position ($p_{\min} = 528$) is absolutely independent on the exposure time of the laser beam, while the leading front changes position and inclination.

All mentioned elements of the scheme are fixed on the surface of the thermostat the temperature of which can be changed within 20 °C–30 °C (at the stabilisation of temperature within ~ 0.01 °C).

To determine the RI resolution of our device, we explore well-known dependence of RI of water on temperature [2]. Dependence of CCD-sensor photoresponse on temperature of water variations is shown in Fig. 3.

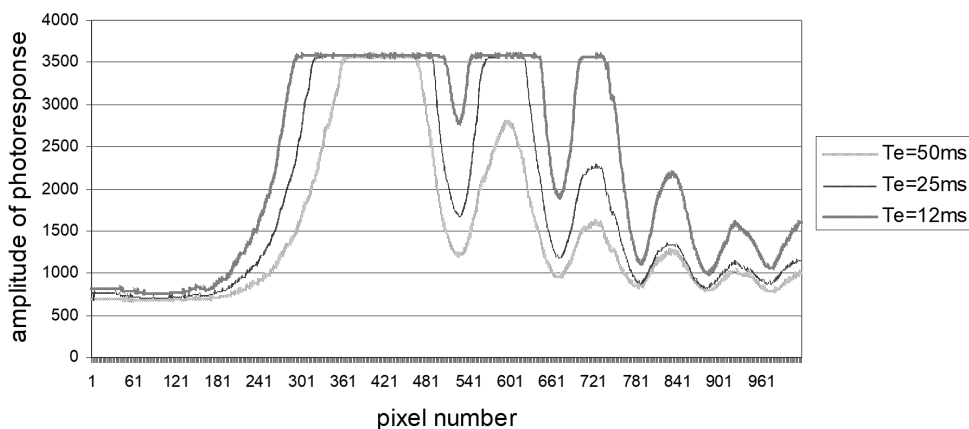

Fig. 2. Dependence of CCD-sensor signals on exposure time T_e of laser illumination.

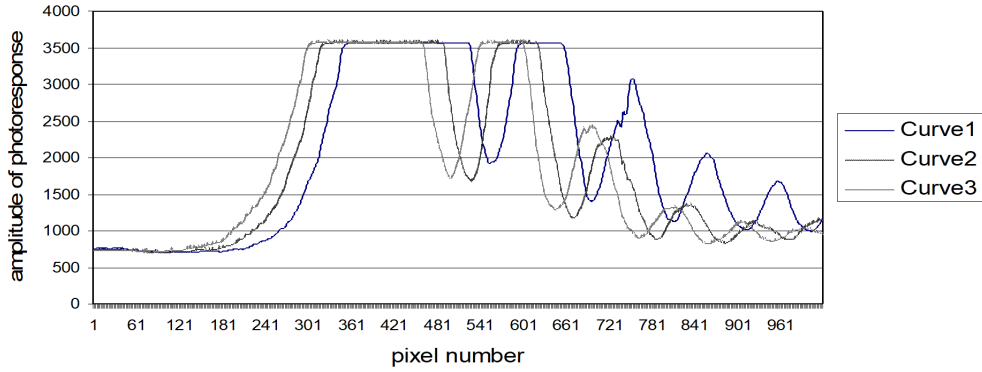

Fig. 3. Temperature dependence of CCD-sensor signal ($T_e=25\text{ms}$): curve 1 – 26°C . ($p_{\min} = 559$), curve 2 – 27°C ($p_{\min} = 528$) and curve 3 – 28°C ($p_{\min} = 500$).

The temperature dependence of a refractive index of water obtained in such a way is used to estimate resolution of our device: sensor signal shift on 1 pixel corresponds to a change in RI of a sample at a value $\approx 4 \cdot 10^{-6}$

3. RESULTS AND DISCUSSION

For preparation of aqueous suspensions, we used SiO_2 nanoparticles from US Research Nanomaterials, Inc. with a mean size of 70 nm: 36 mg of nanoparticles were mixed up in 100 ml of triple distilled water. Then 0.5 ml of suspension was placed into measuring cuvette.

Measurements were carried at the temperature of 27°C . We investigated a change in the shape of a signal of sensors at different exposure times. The obtained data are given in Fig. 4.

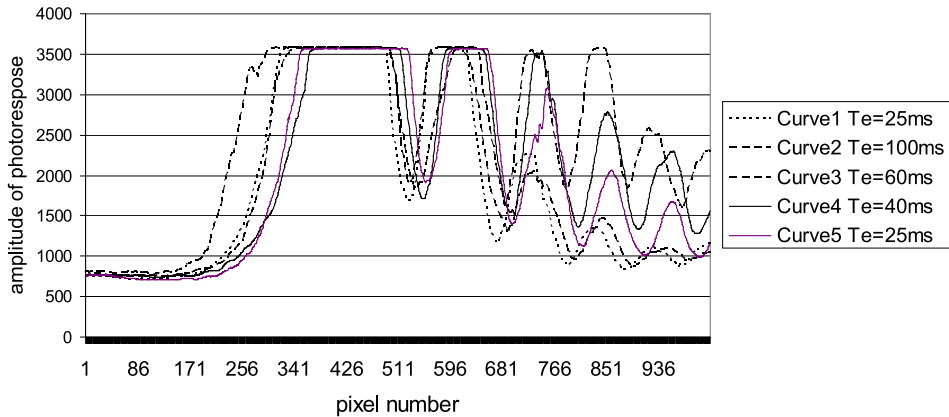

Fig. 4. Dependence of CCD-sensor signals on concentration of SiO_2 nanoparticles in distilled water: curve 1 – water at 27°C ($p_{\min} = 528$), curve 2 – 360mg/l ($p_{\min} = 543$), curve 3 – 180mg/l ($p_{\min} = 551$), curve 4 – 90mg/l ($p_{\min} = 555$), curve 5 – water at 26°C ($p_{\min} = 559$).

Propagation of light in the turbid media is followed by its scattering and absorption. In our case it leads to a decrease in the amplitude of a signal of sensors. As seen in Fig. 4, with an increase in exposure time duration of impulse of laser radiation – the form of a signal takes a nearby signal form, as in the transparent medium. As seen in Fig. 4, the shape of the leading edge is similar, but differs from one another in slope. When we take the first minimum for the criterion, the readings are made unambiguous. On the basis of the measurements described above, we obtained dependence of concentration of nanoparticles on pixel number of CCD-sensor (Fig. 5).

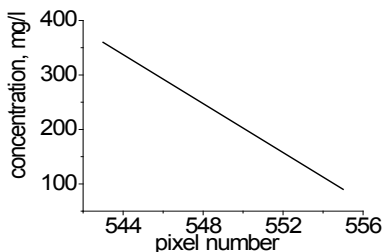

Fig. 5. Dependence of concentration of SiO₂ nanoparticles (mg/l) on the pixel number of CCD- sensor.

The detailed description of propagation of light in the liquids containing nanoparticles has to be described within Mie's theory [11]. By means of this theory, the phase shifts (and the change in refractivity connected with it [10]) arising at light scattering by nanoparticles can be calculated. But in case of suspensions with the small maintenance of SiO₂ nanoparticles as in our case, it is possible to describe light propagation by means of some efficient dielectric constant [12], [13]:

$$\varepsilon_s = \varepsilon_l + c \cdot 3 \cdot (\varepsilon_p - \varepsilon_l) \cdot \varepsilon_l / (\varepsilon_p + 2 \cdot \varepsilon_l), \quad (2)$$

where ε_s , ε_l , ε_p – dielectric constants of suspension, liquid and nanoparticle; c – concentration of nanoparticles in liquid. Since $RI^2 = \varepsilon_s$, at small values of c , as in our case, c must be proportional to RI (see Fig. 5).

4. CONCLUSION

In the present research, we have experimentally confirmed the results of the previous research [4], i.e., the device developed by us – a refractometer – allows measuring concentration of nanoparticles in suspensions up to several mg/l.

It has also been experimentally confirmed that using the unique properties of the new refractometer, especially, where an optical beam refraction and multiple reflections in a cylindrical cell are used and a measurement method, where a minimum place of the detectable beam interference pattern has been used, it is possible to reduce the laser beam motion inside the device by almost 4 times without losing its resolution [4].

REFERENCES

1. Hoo, C. M., Starostin, N., West, P., & Mecartney, M. L. (2008). Comparison of AFM and DLS methods to characterize nanoparticles size distribution. *J. Nanoparticles Res.*, 89–96.
2. Ioffe, B.V. (1974). *Refractometric methods in chemistry* (2nd ed.). Khimya. (in Russian).
3. Kozlov, V., Merkulov, D., & Merkulova, V. (2016). Determination of concentration of nanoparticles in liquids by laser-diode refractometer. *Book of Abstracts of 19th International Conference on Quantum Electronics "Laser physics and applications"* Sozopol, Bulgaria, 91–92.
4. Vilitis, O., Merkulovs, D., & Kozlovs, V. (2017). Measurement of low concentration of nanosized objects in bioliquids by means of refractometric methods. In *Proceedings of the 13th International Conference on Medical Physics "Medical physics in the Baltic states"*, Kaunas, Lithuania (pp. 132–136).
5. Vilitis, O., Merkulov, D., & Kozlov, V. (2003). *Method and refractometer for measuring refractive index of liquids*. Patent LV13294 B.
6. Vilitis, O., & Merkulov, D. (2006). *Method for detecting optical image of the light beam in refractometer*. Patent LV 13598 B.
7. Vilitis, O., Merkulov, D., & Shipkovs, P. (2007). *Method and sensor for measuring concentration of liquids*. Patent LV 13728B.
8. Vilitis, O., Shipkovs, P., & Merkulov, D. (2008). Determination of refractive index of liquids using a cylindrical cuvette. *Latv.J.Phys.Technol.Sci.* 3, 50–62.
9. Vilitis, O., Shipkovs, P., & Merkulovs, D. (2009). Determining the liquids refractive index by using a cylindrical cuvette. *Measurements Science and Technology*, 20, 117001, doi:10.1088/0957-0233/20/11/117001.
10. Jackson, J. D. (1998). *Classic electrodynamics* (3rd ed.). New York: John Wiley & Sons.
11. Bohren, G.F., & Huffman, D.R. (1983). *Absorption and scattering of light by small particles*. New York: John Wiley & Sons.
12. Novotny, L., & Hecht, B. (2006). *Principles of nanooptics*. Cambridge: Cambridge University Press.
13. Landau, L., & Lifshitz, E. (1982). *Electrodynamics of continuous media*. Nauka. (in Russian).

ZEMU KONCENTRĀCIJU NOTEIKŠANA NANOIZMĒRU OBJEKTIEM, KAS SUSPENDĒTI ŠĶIDRĀ VIDĒ

D. Merkulovs, O. Vilītis, V. Kozlovs

K o p s a v i l k u m s

Izstrādāta un izveidota refraktometriska mērīšanas sistēma, kas ļauj panākt temperatūras stabilizāciju 10^{-2} °C un nodrošina mēramā parauga laušanas koeficienta mērīšanas precizitāti ne zemāku par 10^{-5} ; tādējādi tiek sniegta iespēja novērtēt zemas koncentrācijas nanoizmēra objektu, piemēram SiO₂ nanodaļiņu koncentrāciju ūdenī, nosakot šīs suspensijas laušanas koeficientu.

12.03.2018.